

flexyPage Monitor Controller

Boxed CAN R3

Product Datasheet



Content

[Content](#)

[Introduction](#)

[About flexyPage documentation](#)

[Area of application for flexyPage Monitor Controller](#)

[Safety instructions and restrictions](#)

[Installation and maintenance](#)

[Ambient conditions](#)

[Installation](#)

[Assembling](#)

[Electrical connectors, interfaces and LEDs](#)

[Label](#)

[Graphics connector HDMI](#)

[USB](#)

[Ethernet interface](#)

[User LED](#)

[RS232 Debug](#)

[Multi connector](#)

[CAN](#)

[RS232 \(optional\)](#)

[RS485](#)

[Digital inputs and outputs](#)

[Power supply](#)

[Audio](#)

[microSD card](#)

[Principle drawing](#)

[Maintenance](#)

[Dust](#)

[Humidity](#)

[Security software updates](#)

[Technical data](#)

[Power requirements](#)

[Environmental specifications](#)

[Physical dimensions](#)

[Dimensions](#)

[EMC cable installation](#)

[Product history hardware](#)

[Product history software](#)

[Manual history](#)

[Your contact persons at ELFIN](#)

Introduction

flexyPage is a modern and flexible system for the simultaneous display of lift data and multimedia presentations in and outside of lifts.

The flexyPage Monitor Controller Boxed CAN R3 was developed to control displays and TVs in lifts using a HDMI interface. Due to integrated CAN interface external sensors, in- and output modules and controllers can be connected when supporting the standard CANopen CiA 417 - CANopen-Lift. The audio signal is provided through a line-out interface. Using the USB interfaces, different touch sensors can be connected. The configuration and connection to the Internet is provided by the LAN interface.

flexyPage Monitor Controller Boxed CAN R3 can control several monitors with sizes from 10,1" up to 95". They can be used in all lifts and for various use cases, in both newly constructed buildings or for retrofitting.

The flexyPage's layout and functions are freely configurable, which can be also done via Internet. Therefore, no specific software is needed the configuration is done using your usual browser.



Do you have questions or suggestions? Contact us on sales@flexyPage.de.

About flexyPage documentation

This document provides an overview of possibilities of what can be realised with the flexyPage system. It constitutes only a small part of the whole documentation and is undergoing continual improvement.

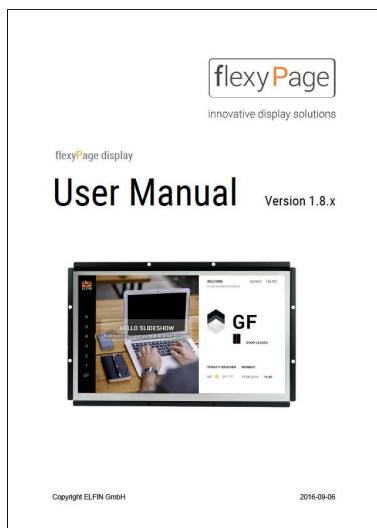

The documents, images, graphics and videos, as well as hard and software are protected by copyright. It is prohibited to copy or circulate this document without prior written consent. Translations do also require a written declaration of consent. The ELFIN GmbH is sole contact regarding copies, translations and similar concerns.

This documentation is continuously revised and updated with the greatest of care. Nevertheless, errors cannot be excluded. We are pleased to hear your comments, helpful references and suggestions about this documentation. Please contact our sales department or support for that.

The ELFIN GmbH will not accept any liability for errors or any potential damage and their consequences in conjunction with delivery or usage of this document.

Please carefully read the user manuals, product data sheets, safety instructions and mounting instructions before using!



The actual user manual as well as other documents and application cases can be found at the product website:

Introduction to the flexyPage system

Quick starting guide

Video tutorials

flexyPage user manual

Widget descriptions

Product data sheets

Frequently asked questions

Sales contact

Support contact

flexypage.de/en/documentation

flexypage.de/en/documentation

flexypage.de/en/tags/video-tutorials

flexypage.de/en/documentation

flexypage.de/en/doc/widget-descriptions

flexypage.de/en/documentation

flexypage.de/en/faq

flexypage.de/en/sales

flexypage.de/en/support

Area of application for flexyPage Monitor Controller

The flexyPage displays were designed for use in lifts. They can be installed in new constructed buildings and in context of modernisation measures for lifts of all manufacturers. The displays can be used in both the lift's cabin and on the buildings floors. Several interfaces, modules and sensors can be used for controlling.

The flexyPage Monitor Controller Boxed CAN R3 was developed to control external displays or TVs using a HDMI interface. It supports different sizes, models and resolutions. You can find the requests concerning the environmental conditions and power supply in the attachment.

Safety instructions and restrictions



Precisely follow this document's instructions, as well as the ones you will find on the device. An exclamation mark inside a warning triangle points out that warnings and hints are available, whose disregard may lead to danger or material damage.



The flash with an arrow leads your attention to dangerous voltage. Disregarding this warning can be life- endangering.

Installation and startup is limited to professionals after having read the whole product documentation! Restoration of damaged assemblies is only permitted for the ELFIN support. An autonomous opening of the encasement may damage the device which automatically leads to the loss of the warranty claim. If the device is already damaged when delivered, do not connect it to the power supply and contact the ELFIN support!

Do not use any caustic cleaning material and avoid installing sharp devices to the glass.

Heat accumulation may cause an overheating of the flexyPage Monitor Controller and displays, which may lead to damages. The internal electricity is cooled passively using the enclosure. If this includes louvers, ensure that these are always unobstructed, so that a sufficient air circulation is provided.

Wetness and liquids can also cause bypasses or electrical shocks. Therefore, only make use of and connect the device inside a building. Ensure that liquids and carrying elements do not come in touch with the device.

Installation and maintenance



Danger: Electrical Shock

Danger to life.

This product operates with 9..32 V DC SELV power supply. Do not connect this product to an improper power supply.



Danger: Electrical Shock

Danger to life.

The IO interfaces (connectors) of the product are only suited to be connected to SELV circuits. Use interfaces (connectors) for their intended use only.



Caution: Explosive Risk

The installed computer board is equipped with a Lithium battery.

Danger of explosion if battery is incorrectly replaced. Replace only with battery of the same or equivalent type.



Warning: Burns Hazard

The product generates considerable amount of heat. The housing transports this heat to the environment and therefore gets hot. Caution when touching the housing, burns hazard!

Ambient conditions



Caution: Damage

Do not operate the product beyond the specified ambient conditions



Danger: Explosive Risk

Do not operate the product in potentially explosive atmosphere.

Installation

Assembling

The emPC-A/RPI is intended for wall and 35mm DIN-rail mount, but can as well be used on the desk-top. Refer to figure below for the recommended mounting orientation.

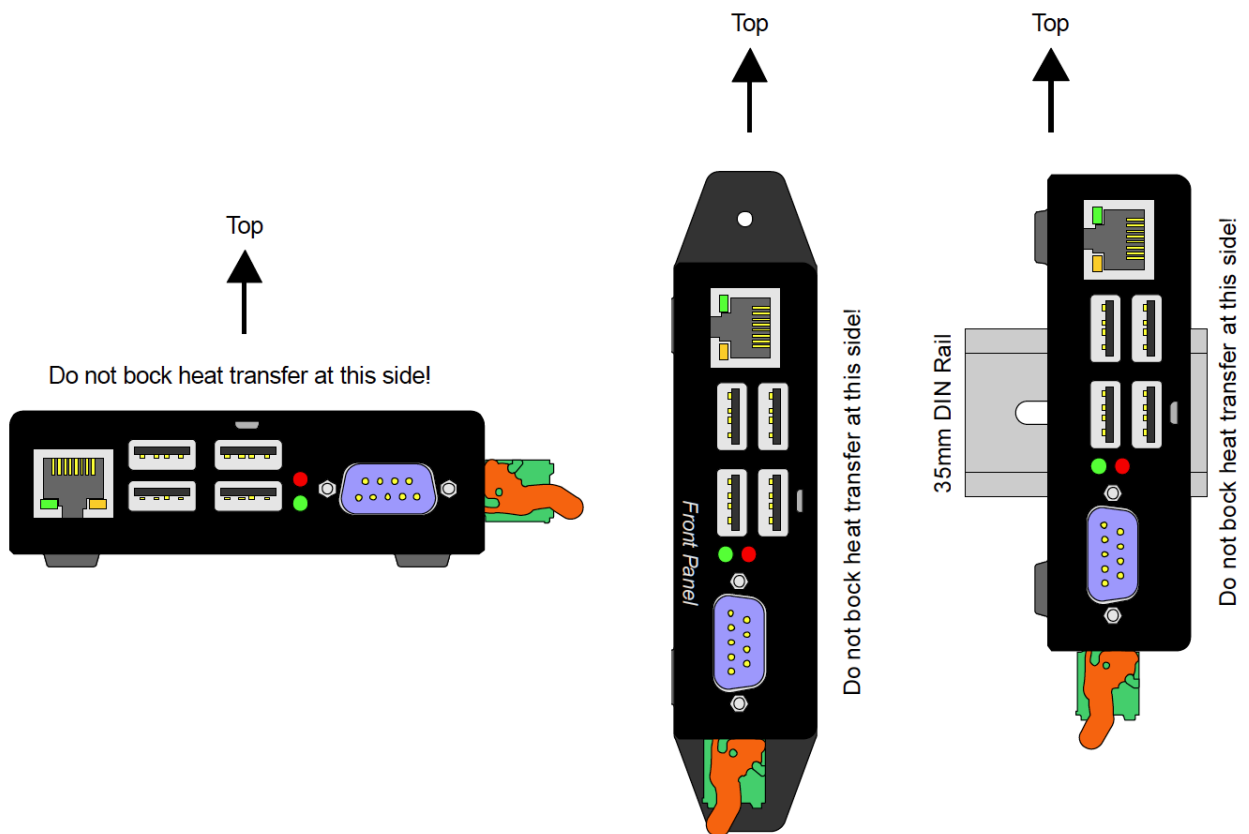

Figure: Recommended installation directions for the flexyPage Monitor Controller Boxed CAN R3

Electrical connectors, interfaces and LEDs

Label

Label with product information
Serial Nr.
IP address
Termination

Graphics connector HDMI

You can connect an external monitor using the integrated HDMI interface which supports the standard HDMI 1.4.

USB

The device provides 4 USB 2.0 (high speed) interfaces. They can be used for both, connecting touch sensors or USB sticks.

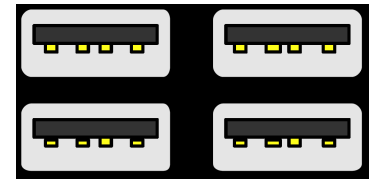

Note: Load

Although each port can deliver supply current of 500 mA, the overall load on USB1 to USB4 interfaces must be limited to 1000 mA to prevent power supply from overheating. If you draw excessive power from USB ports or short circuit USB power supply outputs, then the display controller will temporarily shut off the USB power supply and retry every 2 seconds.

Ethernet interface

For configuration and internet connection the device provides an Ethernet interface 10/100 MBit. The standard interface parameter you can find at the label on top of it. The two LEDs indicate Ethernet status as follows:

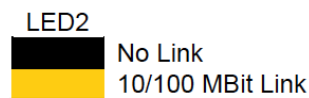
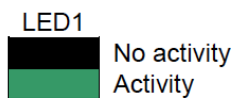
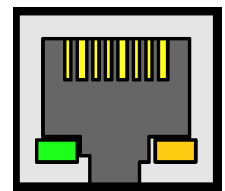

Notice: Cable Length

If your Ethernet cable is long (normative limit = 30 m) or leaves a building, then an additional protection against surges is required.

Add an external surge protector in such cases. E.g. ground the Ethernet cable shield where it enters the building or your cabinet.

If you just connect to a nearby switch, such countermeasures are not required.

User LED

Two user LEDs are located next to the USB interfaces. They indicate internal system states.

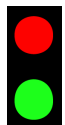

RS232 Debug

At the device's front, a RS232 interface is located, which is currently for development intentions only.

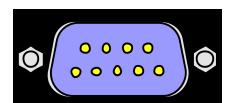

Multi connector

Some signals and interfaces are provided by a multi connector. You can use the following connectors: Phoenix Contact ArtNr. 1790580 and Phoenix Contact ArtNr. 1790399

CAN

The CAN interface is implemented with a MCP2515 controller chip. The interfaces is located on the multi connector, refer to table 6. The CAN interface signals support ISO 11898-2 (high speed) and are isolated from system logic.

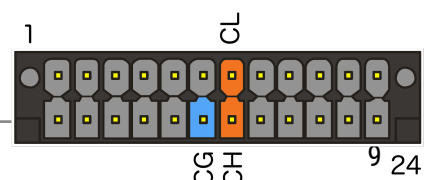

11	n.c.	12	CAN-GND (CG)
13	CAN-L (CL)	14	CAN-H (CH)

RS232 (optional)

The multi connector provides the option to use a RS232 interface instead of a RS458.

5		6	GND
7	CTS	8	RxD
9	RTS	10	TxD

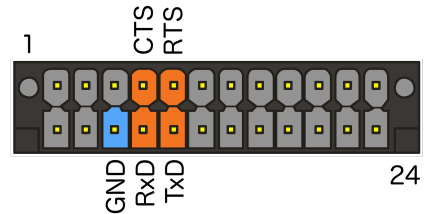

RS485.

In the RS485 mode the bidirectional differential signals D+ and D- are provided. The interface is terminated with 120 Ohm. It is optional to receive an interface without any termination.

5		6	GND
7		8	
9	D- (A)	10	D+ (B)

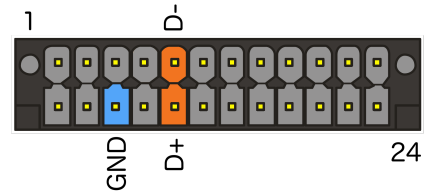

Digital inputs and outputs

Four digital input and output ports are provided on the multi connector.

15	I1	16	I2
17	I3	18	I4
19	Vio (12..24 VDC)	20	Gio (GND-IO)
21	O1	22	O2
23	O3	24	O4

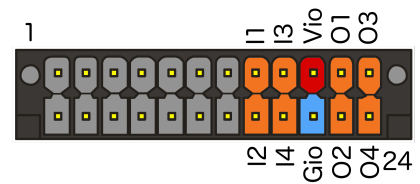

The digital inputs and outputs are isolated from system power supply. Refer following figure for detailed schematic.

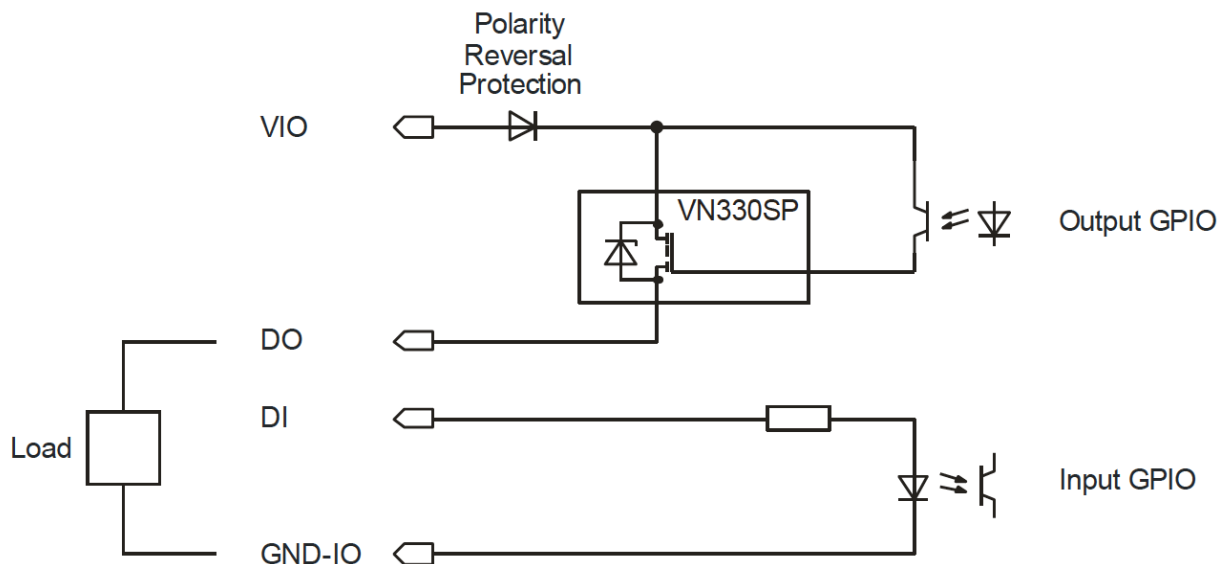

The digital input signals (I1-I4) refer to GND-IO and have an input impedance of about 5 kOhm. Switching level is 6 VDC. The digital inputs do not require Vio to be present.

The digital outputs drive Vio power to the output pins (high side switch). The load must be connected between the output pin and the Gio (GND-IO).



NOTICE: Inductive Load

When using inductive loads the outputs must be protected against high voltage. Add external clamping circuits.

Power supply

The system power supply is located on the multi connector.

1	Vin 12..24 VDC	3	PE
2	GND	4	PE

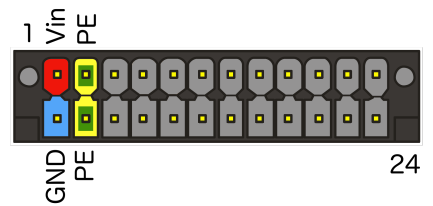

Danger: Electrical Shock

Danger to life.

This product operates with 9..32 V DC SELV power supply. Do not connect this product to an improper power supply.

To protect the device against EMI pins 3 and 4 should be connected to EMI protective earth (PE).

Audio

The line-out signal is provided by a 3,5 mm headphone jack. You can connect speaker to play the voice announcement, background music or a gong.

microSD card

On the back, you can find a microSD card which includes the system software, some parameter and multimedia data. We only use selected, industrial cards. The card was individually developed and cannot be used in different devices!

Principle drawing

The following illustration shows a usual cable system used in an elevator.

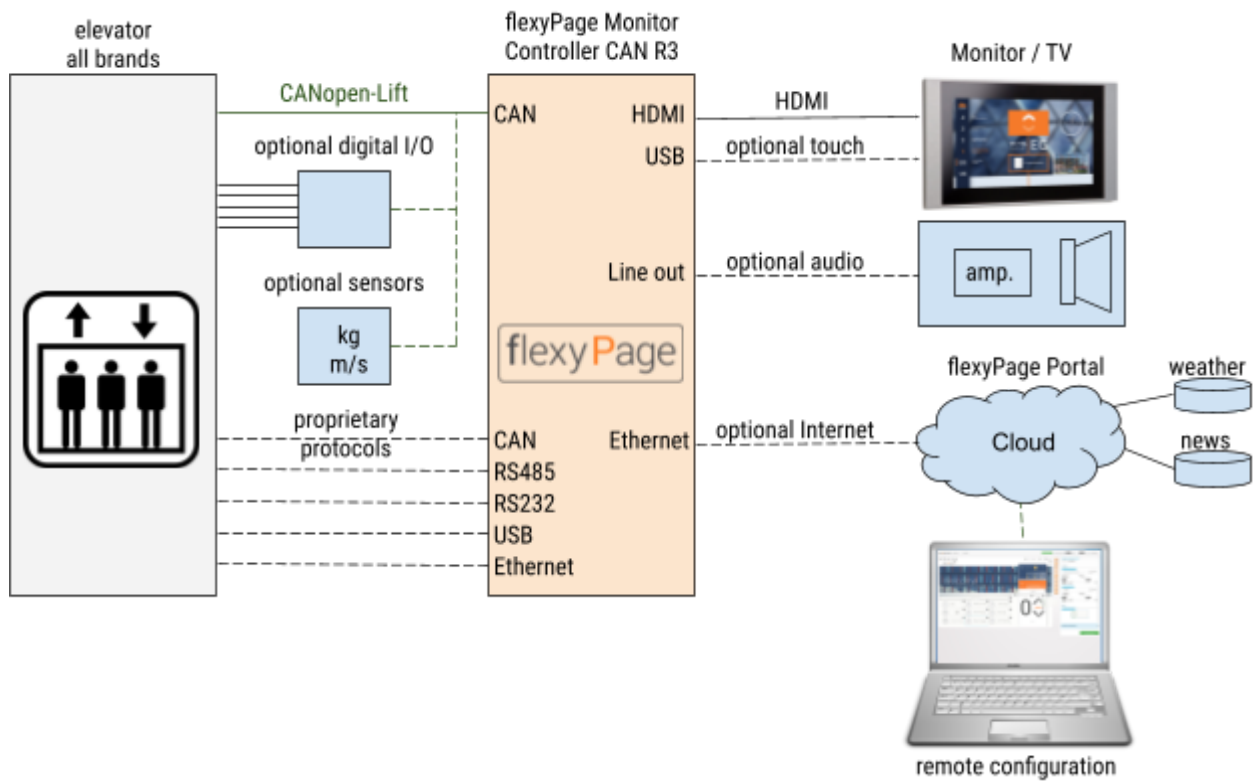

Figure: Principle drawing

Maintenance

NOTICE: ESD Protection

Always follow common ESD practice when you service the product!

Dust

When maintaining the device, ensure that no dust is in there and clean, if necessary.

Humidity

When maintaining, ensure that the device is dry. If not, adopt protective measures.

Security software updates

Security updates may appear to devices connected to the internet. After your log-in, search the category maintenance, check if new updates are available and install them. Further information is available in the user manual. You can also contact our support.

Technical data

ArticleNo.:	fjt2A-01A
Description:	flexyPage Monitor Controller CAN R3
Processor:	CPU: ARM Cortex-A53 (64-bit Quad Core, 1,2 GHz)
GPU:	400 MHz VideoCore IV
Main memory:	1 GB RAM LPDDR2-900 SDRAM
Ethernet:	LAN 10/100 Mbps
USB:	4 x USB 2.0
HDMI:	HDMI 1.4
Storage:	1 x internal MicroSD card (8..32 GB)
CAN:	ISO/DIS 11898-2 (galvanic isolated) internal termination 120 Ohm optional on/off
UART:	1 x RS232 Debug 1 x RS485 (optional 2nd RS232)
Digital I/O:	galvanic isolated 4 x digital inputs 12-24 VDC 4 x digital outputs 12-24 VDC (separate power supply)
Indicators:	2 x User LEDs (red, green)
Housing:	plastic, material: PS 3 mm, class of inflammability UL-V0
Battery:	CR 2032, internal for RTC

Power requirements

Power supply (max):	9 .. 32 V DC
Inv.-pol. protection:	yes, internal
Fuse:	internal melting fuse, 2,5 A in DC in, GND is unfused
potential separation	no, GND is connected to connector shells and PE contact
Inrush current (max):	2,8 A
Energy consumption:	5,1 W (in active mode, without external load or expansion cards) 2,8 W (in standby mode, without external load or expansion cards)

External load

capabilities USB +5V:	max 500 mA per USB port, max 1000 mA for all USB ports
-----------------------	--

Environmental specifications

Operating temperature:	0 .. +45°C at sea level, derated by 1°C per 300 m above sea level to a maximum of 2000 m.
Storage temperature:	0 .. +75°C
Humidity:	5% .. 95%, non condensing
Protection class:	IP20

Physical dimensions

Size (WxHxD):	99,8 x 30,0 x 96,7 mm
Weight:	0,2 kg

The device is according to the current RoHS rules.

Dimensions

The following pictures shows the housing dimensions.

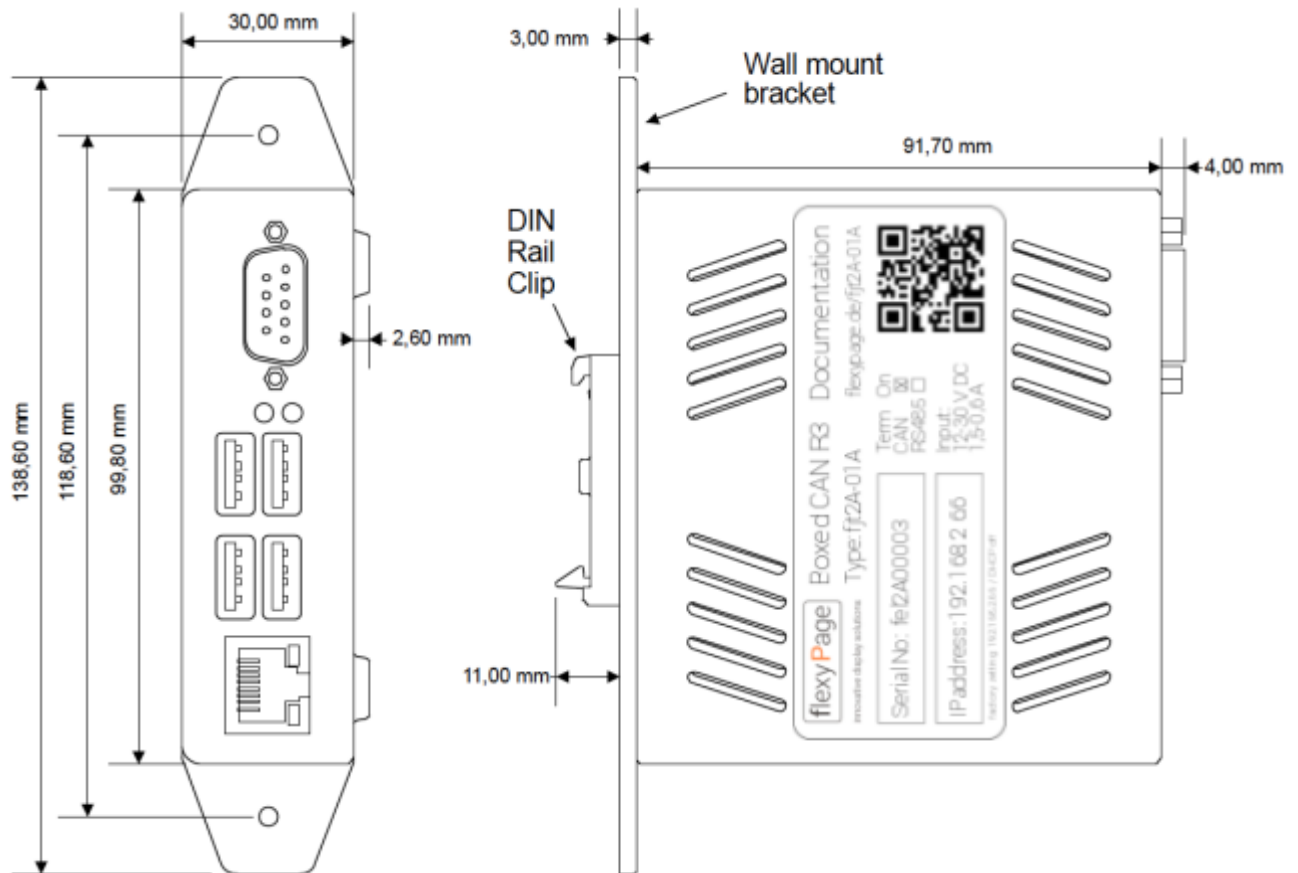

Picture: housing dimensions of flexyPage Monitor Controller Boxed CAN R3

The flexyPage Monitor Controller Boxed CAN R3 is delivered with the following mounting options:

- DIN rail clip (not assembled)
- Wall mount bracket (not assembled)
- Self-adhesive rubber bumpers (not assembled)

Note, that you will not normally use both the DIN rail clip and the wall mount bracket at the same time.

EMC cable installation

The following picture shows the EMC shield (PE) connection for industrial level EMC compatibility.

- Connect PE from the multi connector to the EMC shield (DIN rail).
- Connect cable shields for signals running to the multi connector to the EMC shield (DIN rail).

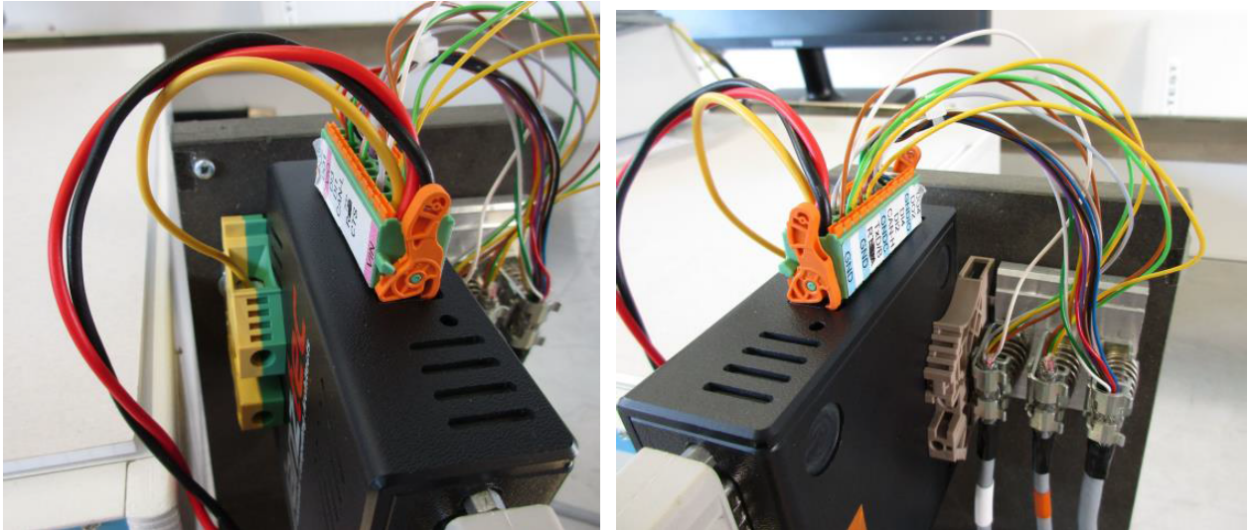

Picture: EMC shielding

Product history hardware

Version	Release Date	Changes
0.9	2016-09-15	Prototype
1.0	2016-09-28	Serial

Product history software

Please have a look at flexypage.de/en/firmware-history

Manual history

Version	Release Date	Changes
0.9	2016-09-26	Pre-version
1.0	2016-09-28	Final version
1.1	2021-03-05	New company name
1.2	2022-03-18	New address

Your contact persons at ELFIN

Even an extensive documentation cannot answer every question. Do you still have questions or suggestions concerning our flexyPage system? We look forward to your requests! Please don't hesitate to contact us at:

ELFIN Technology GmbH

Im Zollhafen 22
50678 Cologne
Germany
Phone: +49 (221) 6778932-0
FAX: +49 (221) 6778932-2
service@elfin.de
www.elfin.de



Sales flexyPage

flexypage.de/en/sales
Phone: +49 (221) 6430816-2
FAX: +49 (221) 6778932-2
sales@flexyPage.de



innovative display solutions

Support flexyPage

flexypage.de/en/support
Phone: +49 (221) 6430816-3
support@flexyPage.de